

BIMETALLIC STEAM TRAPS AND AIR ELIMINATORS

BM 24

(DN ½” – 1” ; DN 15 – 25)

DESCRIPTION

BM24 series bimetallic steam traps and air eliminators are simple and robust traps, recommended for steam process applications where condensate sensible heat can be recovered, steam tracing lines, drip points, storage tank coils, steam air venting, etc. The use of condensate sensible heat reduces the steam consumption.

Connections are female screwed or flanged.

MAIN FEATURES

Modulating discharge.

Discharges condensate below steam temperature.

Excellent air discharge.

Operates on superheated steam.

Unaffected by water hammer and vibrations.

Built-in strainer.



OPTIONS:

Blowdown valve

USE:

Saturated and superheated steam.

AVAILABLE MODELS:

BM24

SIZES: DN ½” to 1” ; DN15 to DN25.

CONNECTIONS: Female screwed ISO 7/1 Rp (BS21)

Flanged EN 1092-1 PN40 or ANSI

INSTALLATION: Horizontal installation recommended, can be installed in any position.

See IMI installation and maintenance instructions.

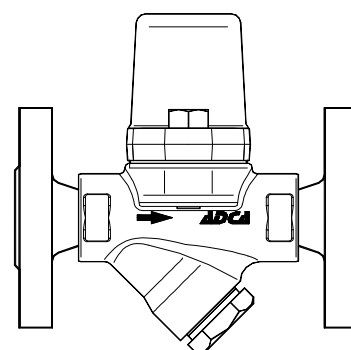
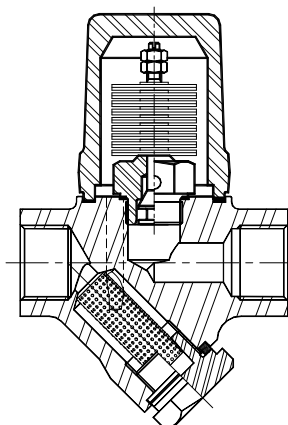

BODY LIMITING CONDITIONS

FLANGED PN40 / ANSI 300 *	FLANGED ANSI 150 **	RELATED TEMP.
ALLOW. PRES.	ALLOW. PRES.	
40 bar	19,3 bar	50 °C
35 bar	15,8 bar	150 °C
30,4 bar	12,1 bar	250 °C
27,6 bar	10,2 bar	300 °C

PMO - Max. operating pressure 24 bar

TMO - Max. operating temperature 250 °C

* According to EN1092-1:2007 ; ** Acc. to EN1759-1:2004

Body limiting conditions PN40 or below, depending on the type of connection adopted. Rating PN40 for thread, SW and BW.

FLOW RATE CAPACITY IN Kgs/h

MODEL	SIZE DN	DIFFERENTIAL PRESSURE (bar)													
		0,5	1	2	4	6	8	10	12	14	16	18	20	22	24
BM24	15 - 25 A	225	350	490	650	720	795	820	850	880	900	905	910	915	925
BM24	15 - 25 B	550	800	1100	1500	1750	1825	2000	2100	2175	2235	2390	2490	2585	2680

A = Condensate discharge at 10°C below saturation temperature. B = Cold water capacity at about 20°C.

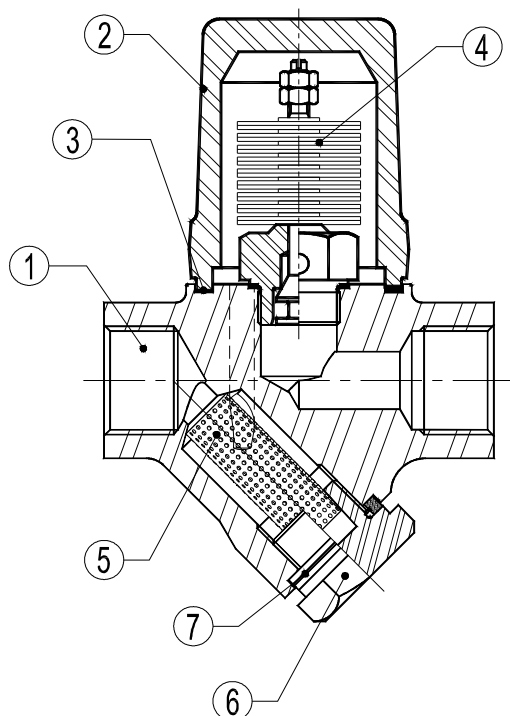

MATERIALS		
POS.N r.	DESIGNATION	MATERIAL
1	Body	P250GH / 1.0460
2	Cover	P250GH / 1.0460
3	* Gasket	St.St./Graphite
4	* Valve assy.	Bimetal
5	* Strainer screen	AISI304 / 1.4301
6	* Cover strainer	A 105 / 1.0432
7	* Gasket	Stainless st./Graphite
8	Bolts	A2-70

* Available spare parts

DIMENSIONS (mm)											
Screwed and SW *						EN PN16/40		ANSI 150		ANSI 300	
SIZE DN	A	B	C	D	WGT. Kgs	E	WGT. Kgs	E	WGT. Kgs	E	WGT. Kgs
15-1/2"	95	59	95	90	2,1	150	3,7	150	3,2	150	4
20-3/4"	95	59	95	90	2,1	150	4,5	150	3,7	150	5,3
25-1"	95	65	95	90	2,1	160	4,9	160	4,5	160	6,1

* BW (butt weld) on request.

