

COMPRESSED AIR BALL FLOAT TRAPS FA16SS (Stainless steel)

DESCRIPTION

FA16SS is a fully automatic ball float trap extremely compact in dimension and light in weight, specially designed for draining water from compressed air lines.

Applications on after coolers, separators and compressed air mains.

Connections are female screwed.

MAIN FEATURES

Corrosion-resistant.

Replaceable internal parts.

Modulating discharge

Unaffected by sudden or wide load and pressure changes.



OPTIONS: Compression fitting
Hand purging valve.

USE: Cold and hot water systems.

AVAILABLE MODELS: FA16SS

SIZES: DN 1/2" and 3/4".

CONNECTIONS: Inlet 1/2" or 3/4" vertical (top to bottom)
Outlet 1/2" vertical.
Female screwed ISO 7/1Rp(BS21)

INSTALLATION: Vertical installation. It must be installed absolutely vertically at the points in the plant where the condensate tends to collect.
The drain should be piped to a safe position.
See IMI installation and maintenance instructions.

APPLICATION LIMITS	
Min. Liquid specific weight	0,75 Kg/dm ³
Maximum working dif. pressure	14 bar

BODY LIMITING CONDITIONS	
Threaded PN16	RELATED TEMP.
ALLOW. PRES.	
16 bar	100 °C
14,5 bar	150 °C
13,4 bar	200 °C
12,7 bar	250 °C

PMO - Max. operating pressure 14 bar
TMO - Max. operating temperature 180 °C

FLOW RATE CAPACITY IN Kg / h														
MODEL	SIZE	DIFFERENTIAL PRESSURE (bar)												
		0,5	1	1,5	2	3	4	6	7	8	9	10	12	14
FA 16SS	1/2"-3/4"	120	145	180	190	230	250	300	330	340	360	380	400	430

MATERIALS		
POS.Nr.	DESIGNATION	MATERIAL
1	Body	CF8M / 1.4408 ; AISI316 / 1.4401
2	Cover	CF8M / 1.4408 ; AISI316 / 1.4401
3	* O-ring	NBR
4	* Seat	AISI 316 / 1.4401
5	* Valve	VITON
6	* Lever	AISI 304 / 1.4301
7	* Float	AISI 304 / 1.4301
8 a)	Compression fitting	Fe / Zn 12 - ISO 2081
9 b)	Hand purging valve	AISI 304 / 1.4301

*Available spare parts.

a) 1/4" x 8 mm compression fitting

b) Hand purging valve

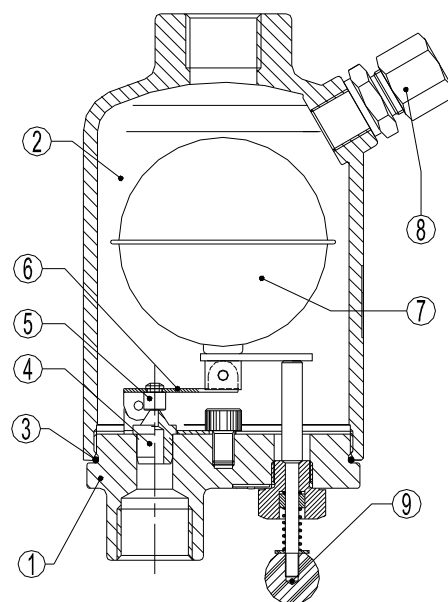

DIMENSIONS (mm)			
SIZE DN	A	B	WGT. Kgs
1/2"	110	152	1,6
3/4"	110	152	1,6

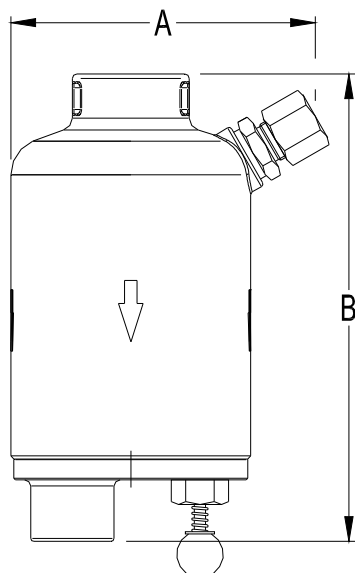

EXAMPLES OF INSTALATION

