



## Combination air valve Mod. EOLO

The CSA combination air valve Eolo will ensure the proper operation of the system allowing the release of air pockets accumulating during working conditions, the entrance and discharge of large volumes of air during pipe draining and filling.



### Technical features and benefits

- Upper and lower bodies in ductile cast iron GJS 500/7 PN 25 rated.
- Float in stainless steel AISI 304 covered with vulcanized NBR.
- Patented air release system with gasket compression control in brass.
- Guiding shaft of the air release system in stainless steel AISI 303/316.
- Nuts and bolts in stainless steel AISI 304/316.
- Simple and compact.

### Applications

- Water distribution systems.
- Irrigation, cooling systems.
- Buildings.
- In general where the air release function is necessary along with a certain air flow capacity, limited to the kinetic passage of this model for which please see the air charts on the next page.

## Technical details

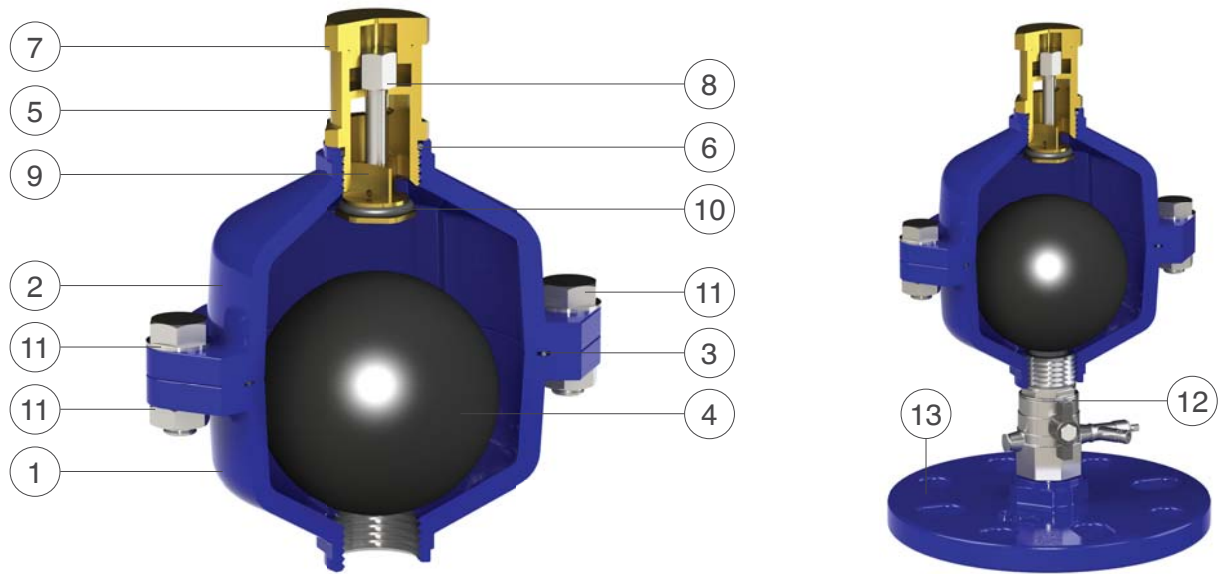

N.	Component	Standard material	Optional
1	Lower body	ductile cast iron GJS 500-7	
2	Upper body	ductile cast iron GJS 500-7	
3	O-ring	NBR	EPDM/Viton/silicone
4	Float	NBR coated stainless steel AISI 304	
5	Nozzle subset body	brass OT58	
6	O-ring	NBR	EPDM/Viton/silicone
7	Nozzle subset tap	brass OT58	
8	Shaft	stainless steel AISI 303	stainless steel AISI 316
9	Nozzle	brass OT58	
10	O-ring	NBR	
11	Screws, washers and bolts	stainless steel AISI 304	stainless steel AISI 316
12	Ball valve	nickel-plated brass OT58	stainless steel AISI 316
13	Flange	ductile cast iron GJS 500-7	painted Fe 37/AISI304/316

The list of materials and components is subject to changes without notice.

### Working conditions

Treated water max. 70°C,  
higher temperature on request;  
Max. pressure 25 bar;  
Min. pressure 0,3 bar.

### Standard

Designed in compliance with EN-1074/4.  
Standard connection 1", flanged on request. Flanges according to EN 1092/2.  
Epoxy painting applies through fluidized bed technology blue RAL 5005.  
Changes and variations on the flanges and painting details available on request.

### Air flow performance charts

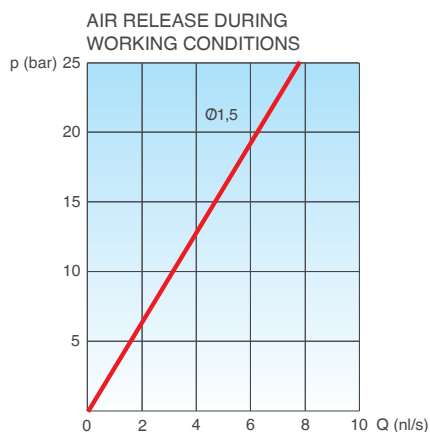

AIR DISCHARGE AND ENTRANCE DURING PIPE FILLING AND DRAINING

$\Delta p$ (bar)	0,1	0,2	0,3	0,4	0,5
Air discharge (m <sup>3</sup> /h)	82	106	120	128	133
Air entrance (m <sup>3</sup> /h)	78	90	118	125	127

