

## Combination air valve with rapid filling preventer mechanism Mod. FOX 3F - RFP

The CSA air valve Mod. FOX 3F RFP will ensure the proper operation of the system allowing the release of air pockets during working conditions and the entrance of large volumes of air during draining. In addition to that this model will always maintain the air outflow within a safety limit, without the risk of water hammer.



### Technical features and benefits

- Uncontrolled pipeline filling operations and transient events will inevitably generate the rapid closure of the air valves installed along the system, with consequent damages. The CSA air valve FOX 3F RFP will automatically adjust the outflow capacity, thus reducing the velocity of the incoming water column minimizing the risk of water hammer.
- The spray effect during closure and the risk of air valve drowning, due to low pressure and possible rapid filling, is avoided.
- Body in ductile cast iron, PN 40 bar rated, provided with internal ribs for consistent and accurate guiding of the mobile block.
- Mobile block composed of the main float and upper disk, joined together by the CSA air release system in AISI 316 (pat. pending), and an additional anti surge obturator.
- Nozzle and gasket holder, part of CSA air release system, entirely made in AISI 316 and designed with gasket compression control to prevent aging process and consequent leakage during working conditions.

### Applications

- Main transmission lines.
- Water distribution networks.
- Irrigation systems.
- In general this model is used, in combination with CSA AS technology, on changes in slope and high points of the profile to provide the best air control and safety of the pipeline.

## Operating principle

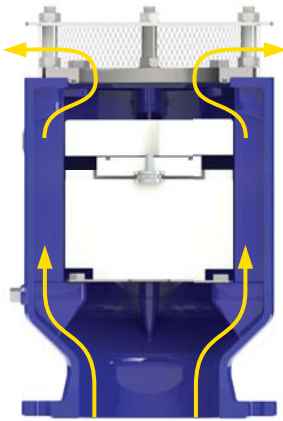

### Discharge of large volumes of air

During the pipe filling it is necessary to discharge air as water flows in. The FOX 3F RFP, thanks to an aerodynamic full port body and deflector, will make sure to avoid premature closures of the mobile block during this phase.

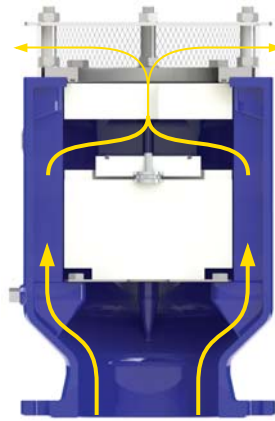

### Controlled outflow

If the differential pressure of air, during pipe filling, increases above a certain value without control there is the risk of water hammer and damages to the system. Should that happen the RFP upper float will rise automatically, reducing the outflow and consequently the velocity of the approaching water column.

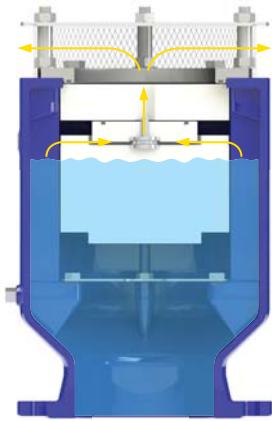

### Air release during working conditions

During operation the air produced by the pipeline is accumulated in the upper part of the air valve. Little by little it is compressed and the pressure arrives to water pressure, therefore its volume increases pushing the water level downwards allowing the air release through the nozzle.

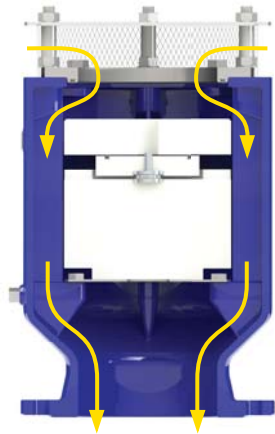

### Entrance of large volumes of air

During pipeline draining, or pipe bursts, it is necessary to bring in as much air as the quantity of outflowing water to avoid negative pressure and serious damages of the pipeline, and to the entire system.

## Optional



■ **Vacuum breaker version Mod. FOX 2F RFP**, to allow the entrance of large volumes of air and the controlled outflow only. This model is normally recommended in changes in slope ascending, long ascending segments, dry fire systems, and wherever the water hammer effect has to be reduced without the necessity of air release.



■ **Version for submerged applications, SUB series**, available both for FOX 3F RFP and 2F RFP Models, with elbow for air conveyance. The design sprang from the necessity of having an air valve performing also in case of flood, without the risk of contaminated water entering the pipeline. Another benefit of SUB is to avoid the spray effect, conveying spurts coming from the closure away from the air valve.



■ **Version for air discharge only EO series**, available both for FOX 3F RFP and 2F RFP models. The most important application of EO is to allow the air valve installation in those locations of the system where HGL may drop below the pipe profile, and to any other node where for project requirements air entrance must be avoided.

## Air flow performance charts

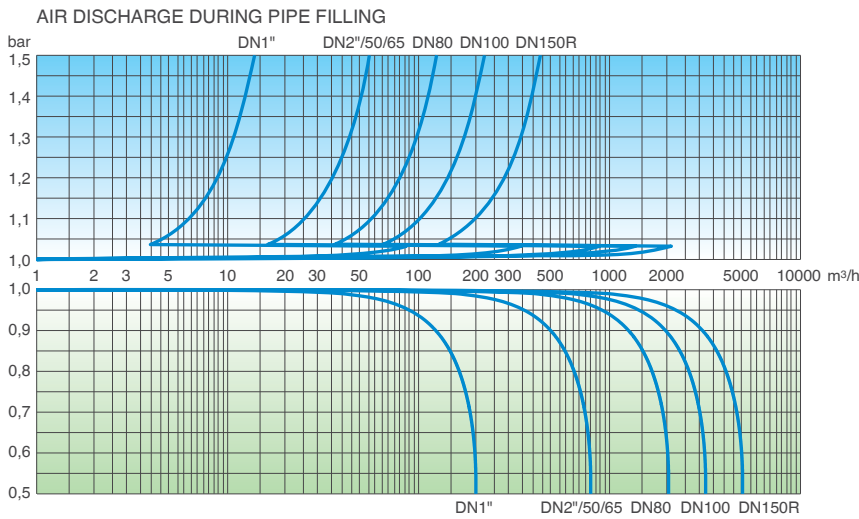

The air flow charts were created in Kg/s from laboratory tests and numerical analysis, then converted using a safety factor.

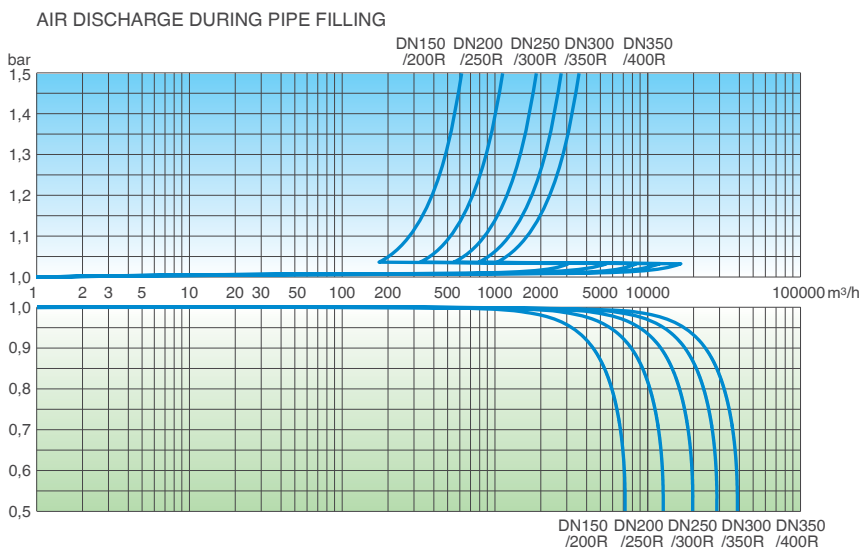
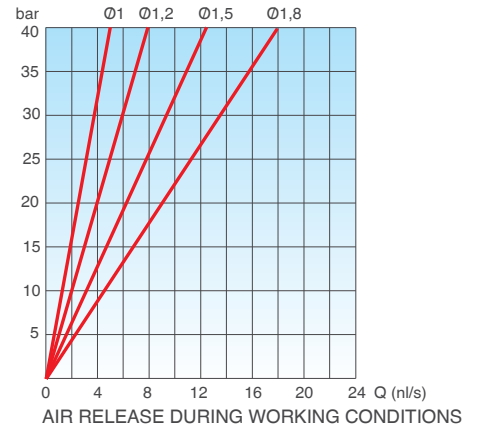

### Working conditions

Treated water max. 60°C;  
 Max. pressure 40 bar;  
 Min. pressure 0,3 bar;  
 Low pressure version to 0,19 bar on request.

### Standard

Designed in compliance with EN-1074/4 and AWWA C-512.  
 Flanges according to EN 1092/2.  
 Epoxy painting applies through fluidized bed technology blue RAL 5005.  
 Changes and variations on the flanges and painting details available on request.

CONNECTION inch/mm	A mm	B mm	C* mm	C** mm	D mm	Weight Kg
Threaded 1"	93	217	=	=	CH 45	3,3
Threaded 2"	118	277	=	=	CH 75	6,1
Flanged 50	118	290	165	165	=	8,1
Flanged 65	118	290	185	185	=	8,6
Flanged 80	142	322	200	205	=	11,1
Flanged 100	180	364	220	235	=	18,5
Flanged 150R	218	435	285	300	=	34,5
Flanged 150	261	500	285	300	=	49,0
Flanged 200R	261	500	340	340	=	51,0
Flanged 200	333	574	340	375	=	94,0
Flanged 250R	333	574	=	400	=	102,0
Flanged 250	414	735	=	450	=	121,0
Flanged 300R	414	735	=	485	=	127,0
Flanged 300	492	850	=	515	=	240,0
Flanged 350R	492	850	=	580	=	250,5
Flanged 350	570	995	=	580	=	295,0
Flanged 400R	570	995	=	660	=	304,0

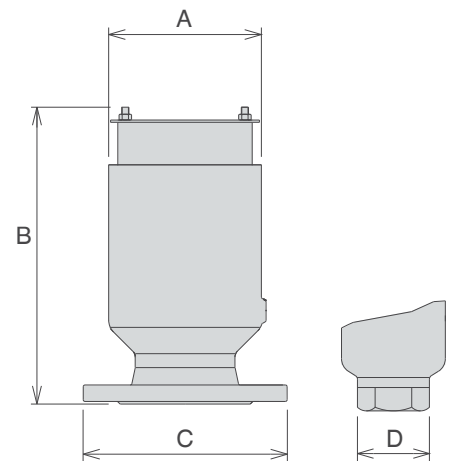

\* M.F. = mobile flanges version  
 \*\* F.F. = fixed flanges version

## Technical details

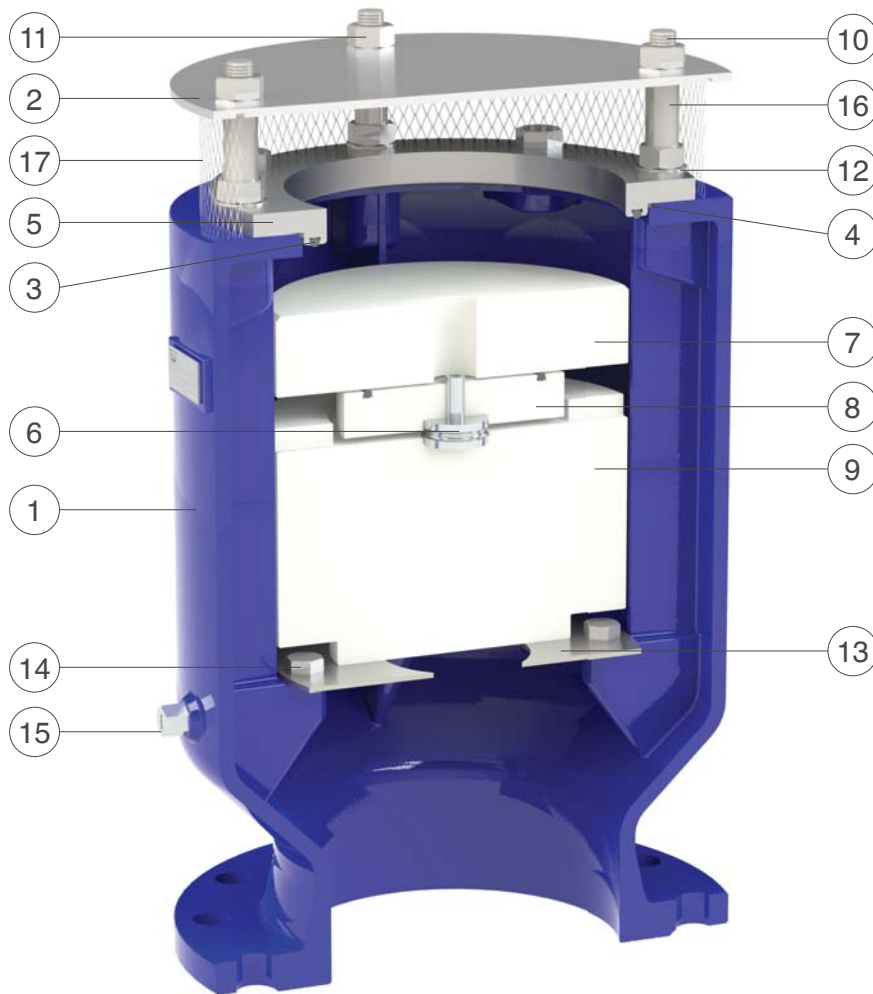

Version with cap and mesh in stainless steel, M series, available from 1" up to DN 400.



Version with cap in ductile, C series, available from 1" up to DN 150.

N.	Component	Standard material	Optional
1	Body	ductile cast iron GJS 500-7	
2	Cap	stainless steel AISI 304	stainless steel AISI 316
3	O-ring	NBR	EPDM/Viton/silicone
4	O-ring	NBR	EPDM/Viton/silicone
5	Seat	stainless steel AISI 304	stainless steel AISI 316
6	Nozzle Subset	stainless steel AISI 316	
7	RFP flat	polypropylene	
8	Upper flat	polypropylene	
9	Float	polypropylene	
10	Studs	stainless steel AISI 304	stainless steel AISI 316
11	Bolts	stainless steel AISI 304	stainless steel AISI 316
12	Washers	stainless steel AISI 304	stainless steel AISI 316
13	Diffuser	stainless steel AISI 304	stainless steel AISI 316
14	Screws	stainless steel AISI 304	stainless steel AISI 316
15	Drain valve	stainless steel AISI 303	stainless steel AISI 316
16	Spacers	stainless steel AISI 304	stainless steel AISI 316
17	Filter	stainless steel AISI 304	

The list of materials and components is subject to changes without notice.